

## 4. ARC WELDING PROCESSES

In arc welding, the joint between the pieces to be assembled is made by filling an appropriate shape (Vee, cross, bell) with a filler metal (rod or wire) which is melted step by step. The joint can be filled in one or more passes. As the filler metal melts, so do the edges of the components that are being joined together (unlike in brazing).

Ever since the arc welding of aluminium in inert gases (argon or helium) came into widespread industrial use, there have always been two main processes but they tend to complement rather than compete with one another (table 48, p. 97). One, TIG, is mainly manual, while the other, MIG, can be fully automated. MIG welding has advanced in great strides since the early Nineties to the point where the conditions under which aluminium is welded are now greatly enhanced.

The mechanical properties of the weld seams are identical in both processes, all other things being equal, i.e. parent alloy, filler metal and material thickness.

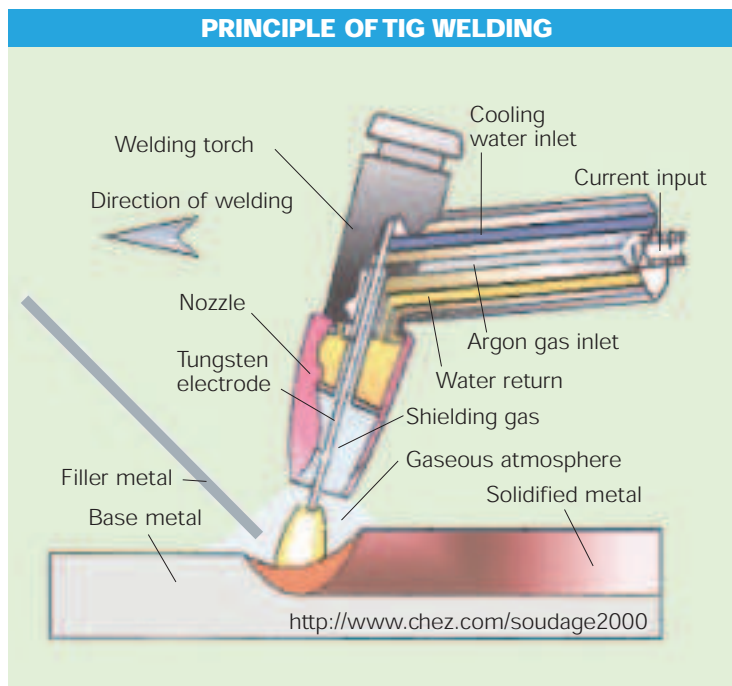

Figure 77

### 4.1 TIG welding (Tungsten Inert Gas)

In TIG welding (16), the electric arc forms between a refractory tungsten electrode and the piece to be welded. The shielding gas – usually argon – is blown out through the nozzle of the torch (figure 77).

In manual TIG welding, the filler metal in the form of a straightened wire rod (0.8 mm to 4.0 mm in diameter) is held manually by the welder. In automated TIG welding, the filler metal is fed automatically

from a reel of wire of diameter 0.8 mm to 2.0 mm by a motorised dispenser.

Welding machines operate with stabilised HF alternating current for manual welding or continuous or pulsed d.c. current for automatic welding. Machines must be fitted with an electronic circuit board designed for aluminium welding, with a pulse arc stabiliser and an arc re-igniter.

The geometry of the refractory electrodes is an important factor influencing the quality of the weld. The electrode must be ground sharp unless the welding machine runs on a.c. current. For d.c. current, the electrode tip must be inside a cone of 30 to 60 degrees, and machining (or grinding) marks must run parallel to the longitudinal axis of the electrode (figure 78).

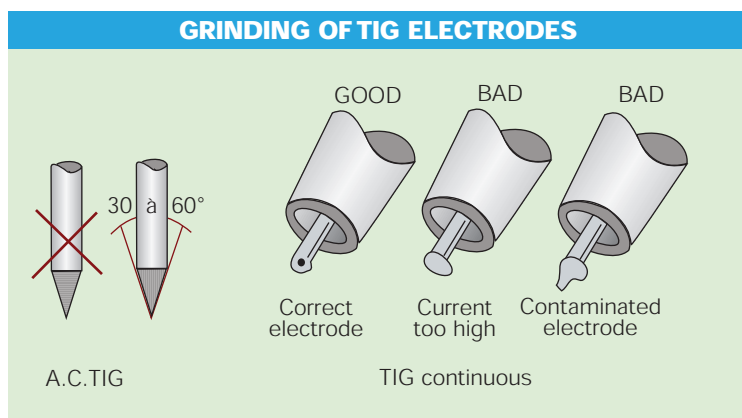

Figure 78

(16) The process is known as WIG in Germany (tungsten in German is 'Wolfram') and GTAW in America (Gas Tungsten Arc Welding).

TIG uses less power than MIG, so the heat affected zone is wider (because of the diffusion coefficient) and there is more distortion due to expansion. The rate of welding which is controlled by the welder is relatively slow, in the region of 0.2 m.min<sup>-1</sup>.

TIG welding is above all a manual process and simple to use, allowing meticulous workmanship and precision results. Welding is possible in all positions. It is suitable for material 1 to 6 mm thick. It can be used to weld with clearances that are over twice the thickness of components under 1.5 mm thick.

TIG is difficult to automate so is limited to use in the development of prototypes and in the repair of defective welds.

## 4.2 | MIG welding (Metal Inert Gas)

In MIG welding (17), the filler wire also acts as the electrode supplying the power (figure 79). The wire is automatically uncoiled from a reel and fed to the welding tool (gun or torch) as it is used up.

The welding power is proportional to the amount of wire that is fed to the weld seam, and is supplied by a d.c. power source which can be continuous or pulsed. Connection is made with reverse polarity, i.e. the workpiece is always connected to the minus (negative) pole to ensure descaling of the oxide film.

MIG welding is 'self-pickling' because the transfer of electrons from the workpiece to the filler wire breaks the oxide film (provided it is very thin, several nanometers).

A thick oxide layer that has formed following long exposure to ambient humidity cannot be fully

removed, and the weld seam will have oxide inclusions (defect 303, cf table 54, p. 104). Semi-finished products should therefore be stored under cover in a dry place (18).

The welding current varies from 40 to 700 Amps depending on a number of parameters such as the diameter of the filler wire, the position of the weld, the size of the components etc.

The classic MIG process using continuous current has many advantages:

- excellent productivity due to the high rate of filler metal deposition,
- good penetration,
- low splatter,
- the process can be automated.

## 4.3 | Synergic pulsed MIG

MIG welding has made great advances since the appearance in the early Eighties of so-called "synergic pulsed current" generators in which the current is supplied by power transistors.

Prior to this, power was supplied by thyristor generators whose pulse frequency was a direct function of the mains frequency. Settings were difficult and lacked flexibility because the speed of the wire had to be adjusted according to the frequency.

Synergic pulsed current generators allow the welding cycle to be regulated (figure 80) to give:

- high current at the start of the weld to avoid lack of fusion and penetration, and
- low current at the end of the weld to prevent crater formation.

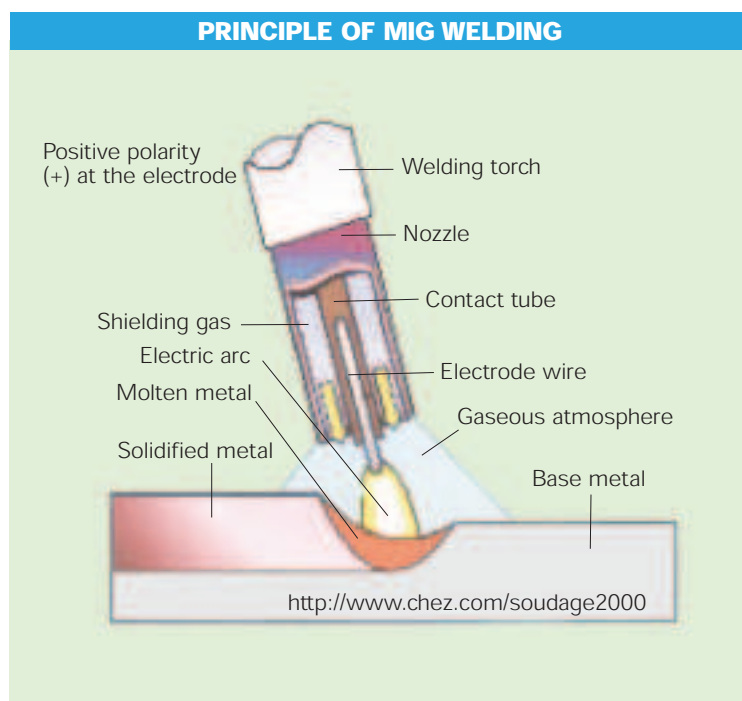

Figure 79

(17) Still also known as MAG (Metal Active Gas) or GMAW (Gas Metal Arc Welding).

(18) Cf. Section 5.

The welder can control three parameters to optimise the weld seam:

- the speed of the wire, proportional to the welding current,
- the welding speed,
- the height of the arc, proportional to the welding voltage.

With these machines, the parameters adjust automatically to the displayed speed of the wire. Settings can be refined by adjusting the height of the arc.

In this system, the metal is transferred "drop by drop" (i.e.

one drop of metal per pulse), allowing the minimum weldable thickness to be reduced from 3 to around 1 mm <sup>(19)</sup>.

Pulsed MIG offers a number of additional benefits over conventional MIG welding with continuous current:

- welds can be made in any position,
- distortion is limited (low power input),
- limited weld repairs and fewer in number,
- wide range of thicknesses with the same diameter wire,

■ good joint quality and good mechanical properties,

■ good appearance of the weld seam, especially with spray transfer,

■ process can be fully automated.

*(19) With the old-type generators the transfer of metal by spraying was only possible at 20 V and over. Below this voltage, globule or short-circuit transfer is unsuited to the welding of aluminium, which accounts for the minimum thickness of 3 mm.*

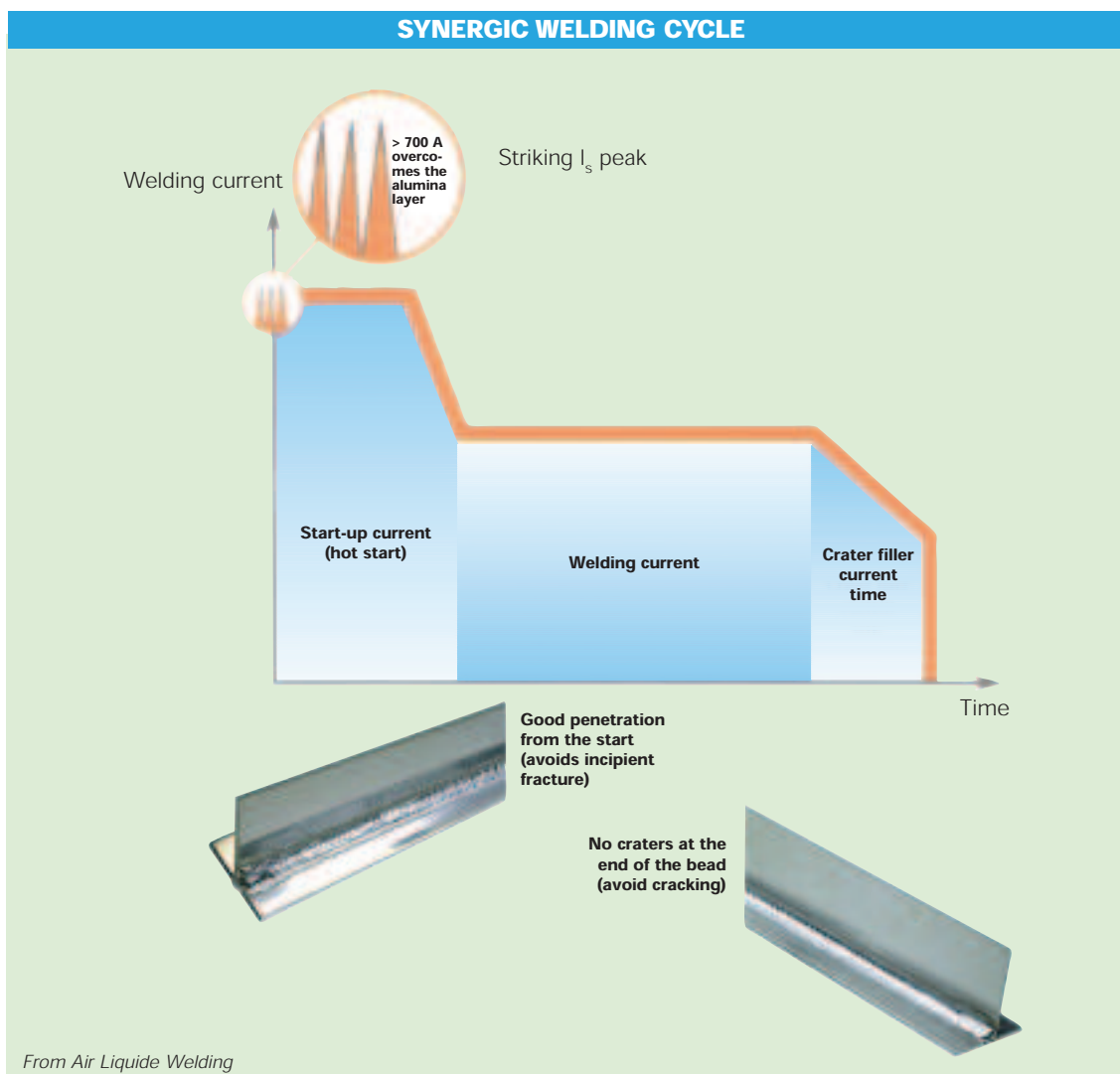

Figure 80

## THE SPRAY-MODAL PROCESS

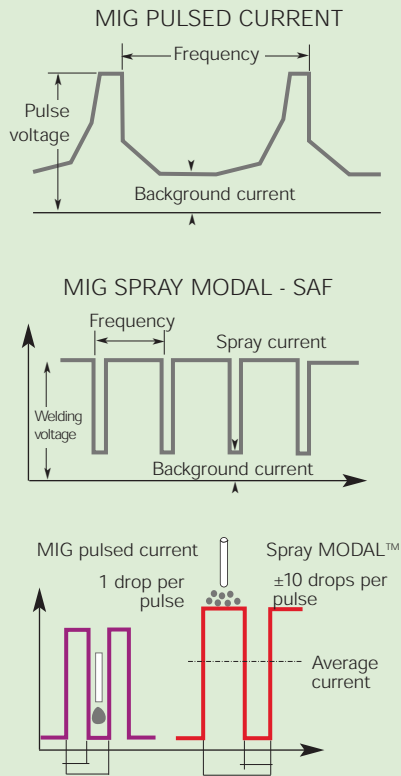

Figure 81

## SURFACE CONDITION OF FILLER WIRES



GX50

From Air liquide Welding

Figure 83

## 4.4 "Spray MODAL" synergic MIG with modulated current

There is now a variant of the synergic welding technique – the "Spray Modal" process (20). It operates with modulated current which falls very rapidly over a very short period of time (several milliseconds) with every pulse during which several drops of filler are projected into the weld pool (figure 81). These rapid variations in voltage within the arc cause the weld pool to vibrate, encouraging the evacuation of hydrogen bubbles from the metal while it is still liquid.

Compared with synergic pulsed MIG, Spray-MODAL welding

- reduces or even eliminates porosity in the weld (figure 82).
- enhances penetration,
- increases welding speed.

## 4.5 Filler wires

An evenly dispensed filler wire will ensure good arc stability and hence the quality of the weld. The low rigidity of the filler wires requires the use of suitable

dispensers to minimise the chances of the wire snagging in the torch tube which must be made of PTFE ("Teflon") to eliminate risks of abrasion.

A torch with a push/pull wire dispensing system is recommended to ensure optimum dispensing regularity, especially when using the 4043A wire grade and in automated welding.

Filler wire is usually 1.2 mm in diameter, although there are also 1.6 mm gauge wires; these are more rigid and their use is growing with pulse MIG. They are also used when the rate of deposition is high.

Shaving the filler wires in the final drawing pass has a number of effects, all of which enhance the quality of the weld:

- it eliminates the outer zone which can be the site of magnesium segregation,
- it removes traces of grease,
- it 'sizes' the weld which removes surface irregularities that are areas of moisture retention (figure 83).

(20) Patented by Air Liquide.

## EFFECT OF SPRAY-MODAL ON POROSITY

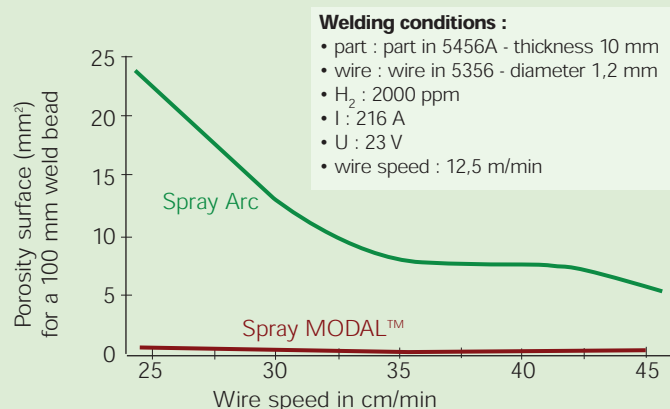

From Air liquide Welding

Figure 82

PARAMETERS OF TIG AND MIGWELDING			
	d.c. TIG	a.c. TIG	d.c. MIG
Current source	Direct	Alternating with HF and arc decay (specially designed for aluminium alloys).	Direct, with very shallow trailing edge. A pulsed source is a good option for slender work.
Electrodes	Zirconium tungsten	Pure tungsten	Filler wire
Torch angle	80° in the direction of advance	80° in the direction of advance	80° in the direction of motion
Gas	Helium	Argon or mixture of 70% argon, 30% helium(*) Flow 10 l/min <sup>-1</sup>	Argon or a mixture of 30% argon, 70% helium (*, **) Flow 1 l/min <sup>-1</sup> for a nozzle 18 to 25 mm in diameter
Welding speed	0.30 to 0.60 m/min <sup>-1</sup>	Slow: 0.15 to 0.30 m/min <sup>-1</sup>	Faster: 0.40 to 1 m/min <sup>-1</sup>
Application	Thickness 0.1 to 10 mm Automated welding with good weld quality	Thickness 1 to 6 mm Prototypes Repairing defective welds	Thickness 1 mm and over, in several passes if necessary All welded fabrications

(\*) The helium in argon/helium mixtures increases the welding speed and improves penetration.

(\*\*) Pulse MIG and Spray MODAL™ synergic MIG methods operate mainly with argon.

Table 48

## 5.

### STORAGE OF SEMI-FINISHED PRODUCTS AND FILLER WIRE

Given aluminium's very strong affinity for hydrogen when in the liquid state (figure 60, p. 86), it is essential to remove all possible sources of that element, especially moisture which can deposit on semis and filler wire in storage and hydrate the oxide layer.

Filler wire is always supplied in sealed packs that must be stored in an enclosed, covered room that is at the same temperature as the welding shop. The packs should not be opened until required for use.

When welding operations are complete, any wire left on the reel must be stored in a cabinet maintained at a constant 40 °C.

## 6. SURFACE PREPARATION

Other sources of hydrogen are the rolling and forming greases and oils left on the surface of the metal, and other impurities of different types, such as traces of paint.

The surface of the metal must therefore be cleaned very carefully on both sides, starting by degreasing with a non-chlorinated solvent to dissolve the greases and oils (21). Solvents are themselves hydrocarbon compounds containing hydrogen atoms, so great care must be taken to ensure no trace is left prior to welding.

After degreasing, the edges must be brushed (after chamfering as necessary) on both sides of the metal and over a sufficient width that is at least equal to the width of the heat affected zone, i.e. 25 mm. A rotary brush with stainless steel wires should be used for this.

Whatever method of brushing is used (manual or mechanical) the brush itself must be very clean and operators must wear gloves.

The "life" of surface preparation is certainly no more than one day, after which time the oxide film may well absorb moisture once more, especially in humid environments (22).

To eliminate moisture, just prior to welding an oxy-acetylene torch can be used to pre-heat the edges at a temperature above dew point in the region of 30 to 40 °C.

## 7. JOINT PREPARATION AND SETUP

These operations are very important, and will determine the quality of the weld and its fatigue resistance. For example, excessive clearance between the workpieces can cause the weld seam to collapse and lead to the formation of undercuts that can be very detrimental to the quality of the weld and its fatigue resistance.

The type of edge preparation will depend on:

- the thickness of the work,
- the type of weld: butt, flat or fillet, vertical, overhead or horizontal,
- the use of a liner, whether permanent or not.

As a general rule, the edges of material up to 4 mm thick are not chamfered.

Ideally, edges that are to be welded should be prepared by machining with a coarse-tooth cutter or if this is not available, manually using a coarse file. Avoid grinding with corundum or resin wheels.

Workpiece configuration is also important; this relates to:

- the clearance between the workpieces – this must be as small as possible (23) to prevent distortion,
- the size and shape of the liner (stainless steel).

Tables 49 and 50 illustrate a number of examples of edge preparation and configuration found in shipbuilding.

## 8. FILLER METAL

The filler metal must be compatible with the chemical composition of the parent alloys that are to be welded, and must ensure the best possible weldability.

The choice will also depend on the mechanical properties and corrosion resistance that the joint is required to have.

For the aluminium alloys that are used in shipbuilding (and other marine applications), the filler metals are:

- silicon alloys, mainly 4043A, 4045, 4047A,
- magnesium alloys, mainly 5356, 5183, 5556A.

Their compositions are shown in table 51, p. 100.

Table 52, p. 101 - taken from EN 1011-4 (24) - shows possible choices of filler metal according to the hierarchy of criteria used for the weld. 5183 is the best filler metal for welding *Sealium*<sup>®</sup>.

(21) Chemical pickling in alkaline baths should be avoided at all cost. Thorough washing is essential and experience shows that this is often inadequate, with a risk of subsequent corrosion by traces of the alkaline medium.

(22) BS 8118 "Structural use of aluminium, Part 2 Specification for materials, workmanship and protection" states that the time between cleaning and welding must not exceed 6 hours.

(23) Zero clearance is the ideal.

(24) Standard EN 1011-4. Welding – Recommendations for welding of metallic materials. Part 4: Arc welding of aluminium and aluminium alloys.

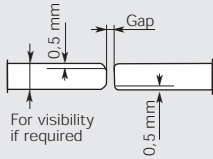
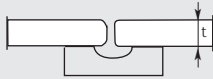
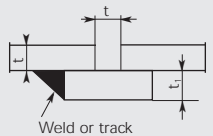
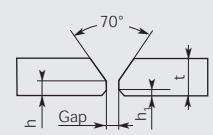
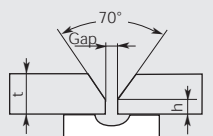
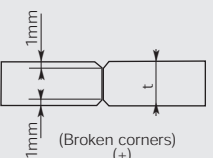
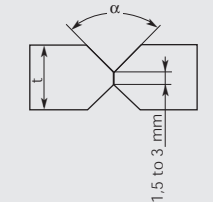
EXAMPLES OF EDGE PREPARATION FOR BUTT WELDING MIG WELDING					
Position	Welding	Liner	Thickness (mm)	Preparation	Remarks
All	1 side only	none	$3 < t \leq 6$		Max. gap 1.5 mm Back-weld advisable for $t > 4$ mm (*)
		temporary			Max. gap 3 mm
		permanent			$t_1 = t + 1$ mm with max. 6 mm
Flat, vertical, overhead	1 side only	none	$3 < t < 25$		Max. gap 1.5 mm Back-weld advisable for $h = 3$ mm (*)
		temporary			Max. gap 2 mm
Flat	2 sides alternately	none	$8 < t < 30$		Material over 12 mm thick should be welded automatically with a high current (+). Improvement and visibility of the weld
Flat, vertical, overhead	2 sides alternately	none	$t > 10$		$\alpha = 70/90^\circ$ for flat and overhead welds $\alpha = 70^\circ$ for vertical welds

(\*) Where a back-weld is advisable, it must be welded after gouging to the base of the first pass.

Table 49

(\*) Taken from standard NF 87-010 "Aluminium et alliages d'aluminium – Soudage – Préparation des bords" (Aluminium and aluminium alloys – Welding – Edge preparation).

## 9. FINISHING

The purpose of weld finishing operations is to:

- repair defective weldments,
- remove any black deposits left by welding,
- correct structures with excessive distortion,

- shave the seam,
- put the seam in compression by shot-peening,
- complete the concavity of the seam.

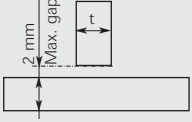
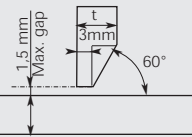
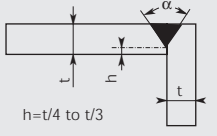
EXAMPLES OF EDGE PREPARATION FOR FILLET WELDS MIG WELDING (WELDS IN ALL POSITIONS, NO LINER)			
Welding	Thickness (mm)	Preparation	Remarks
2 sides alternately or simultaneously, automatic flat welding	$t > 4$		
1 side	$t > 4$		If possible 1 back pass on other side, 5 mm groove (*)
1 side	$t > 6$		$\alpha = 70^\circ$ . Back-weld if possible

(\*) Where a back-weld is advisable, it must be welded after gouging to the base of the first pass.

Table 50

(\*) Taken from standard NF 87-010 "Aluminium et alliages d'aluminium - Soudage - Préparation des bords" (Aluminium and aluminium alloys - Welding - Edge preparation).

CHEMICAL COMPOSITION OF FILLER METALS (*)								
Alloy	Si	Fe	Cu	Mn	Mg	Cr	Zn	Ti
4043A	4,5 6,0	0,6	0,30	0,15	0,20		0,10	0,15
4045	9,0 11,0	0,5	0,30	0,03	0,05		0,10	0,20
4047A	11,0 13,0	0,6	0,30	0,15	0,10		0,20	0,15
5356	0,25	0,40	0,10	0,05 0,20	4,5 5,5	0,05 0,20	0,10	0,06 0,20
5183	0,40	0,40	0,10	0,50 1,0	4,3 5,2	0,05 0,25	0,25	0,15
5556A	0,25	0,40	0,10	0,6 1,0	5,0 5,5	0,05 0,20	0,20	0,05 0,20
5556 (**)	0,25	0,40	0,10	0,50 1,0	4,7 5,5	0,05 0,20	0,25	0,05 0,20

(\*) According to standard EN 573-3, Part 3: Aluminium and aluminium alloys - Chemical composition, except for the 5556.

Table 51

(\*\*) According to the Aluminum Association.



## 9.1 | Repair of defective welds

If inspection (X-ray, ultrasonic etc.) reveals unacceptable weld imperfections then the weld must be repaired.

On material under 4 mm thick, defective areas can be removed with a rotary tungsten carbide cutter mounted in a pneumatic

drill. The axis of rotation of the cutter must be parallel to the axis of the weld so as to avoid incipient cracks.

For material over 4 mm thick, the defective areas should be removed with a pneumatic hammer fitted with a gouge (25).

The weld is then repaired by the same process (TIG or MIG) as was used to make the initial joint.

Minor imperfections are nearly always repaired by TIG welding however, thickness allowing.

(25) Carbon arc gouging is not advisable as it may introduce carbon into the weld seam.

(26) Cf. Chapter 10, Section 10-2.

### CHOICE OF FILLER METALS AS A FUNCTION OF THE ALLOY COMBINATION

Each combination has three possible choices - indicated where the lines intersect - depending on the selected criterion: Optimum mechanical properties: top line - Optimum resistance to corrosion: middle line - Optimum weldability: bottom line

The filler metal indicated is: 4 : series 4xxx → 4043A, 4045, 4047A - 5 : series 5xxx → 5356, 5183, 5556A

<b>Alloy A</b>					
Wrought 5000 Series Mg < 3 %	5 5 (a) 4 - 5 (b)				
Wrought 5000 Series Mg > 3 % (a)	5 5 5	5 5 5			
Wrought 6000 Series	5 - 4 5 4	5 - 4 5 4	5 - 4 5 4		
Wrought 7000 Series without copper	5 - 4 5 4	5 - 4 5 4	5 - 4 5 4	5 - 4	
Cast Si > 7 % (c)	4 (e) 4 4	5 - 4 (e) 5 4	4 4 4	4	4 (d) 4 4
<b>Alloy B</b>	Wrought 5000 Series Mg < 3 %	Wrought 5000 Series Mg > 3 %	Wrought 6000 Series	Wrought 7000 Series without copper	Cast Si > 7 % (c)

(a) 5000 series alloys with more than 3.5 % Mg are sensitive to intergranular corrosion when exposed to temperatures over 65°C and when used in certain aggressive environments (26).

(b) 5000 series alloys with less than 3 % Mg and 3000 series alloys that contain magnesium may be sensitive to hot cracking.

(c) The mechanical performance of the weld depends on the internal soundness of the castings. Gassed materials and injection mouldings are considered to be non-weldable.

(d) The percentage of silicon in the filler wire must be as near as possible to that in the casting.

(e) The welding of aluminium-silicon castings (40000 series) to 5000 series alloys should be avoided where possible as Mg<sub>2</sub>Si intermetallics form in the weldment and weaken the joint.

Table 52

## 9.2 | Cleaning

Very fine black deposits of "soot" can often be seen sticking to the surface of the metal at the edge of the weld seam after MIG welding, especially when 5000 series semis are welded with 5356 alloy as the filler metal.

4043A filler wire leaves no deposits (except possibly at the start and finish of the weld) provided the welding equipment is set correctly.

This "soot" consists of particles of oxides (of aluminium and magnesium) caused by small amounts of filler metal vaporising in the arc,

the temperature of the arc being higher than the boiling point of aluminium and magnesium. The vapour immediately condenses on cold parts of the sheet near to the weld.

These deposits only affect the appearance of the weld and have no impact on its mechanical properties or corrosion resistance.

This "soot" can be brushed off with a metal brush. This should be done as soon as possible after welding as it becomes much more difficult to remove if left for several hours.

## 9.4 | Shaving

Shaving the weld seam very significantly improves the fatigue resistance of the joint provided the seam is free from internal flaws which shaving would expose.

According to BS 8118 for example, shaving increases the endurance limit of a seam from 24 MPa for a 120° angle to 50 MPa for a shaved seam (27).

Welds are normally shaved with a fine abrasive wheel (50 to 80 grit).

## 9.3 | Correcting distortion

Minor distortion in sheet under 3 mm thick can be corrected with a hammer or mallet.

When sheets are bulged (figure 84), the welding torch can be used to apply "shrinkage heat" as locally as possible to the bulges. The heat makes these constrained areas expand (the welded zones are shorter than the sheet), and they are compressed. Rapid cooling – with a jet of water if necessary – then causes shrinkage which places the piece under stress and so corrects the warp. "Shrinkage heat" may also be combined with hammering.

## 9.5 | Shot-peening

Shot-peening a weld seam puts its surface in compression, neutralising internal stresses detrimental to the weldment's fatigue strength.

Different types of shot can be used – glass, ceramic or steel – but it is the latter two which significantly enhance fatigue strength (figure 85).

Although there is no way of verifying the efficiency of these treatments, they can be applied to the welds of "hot spots".

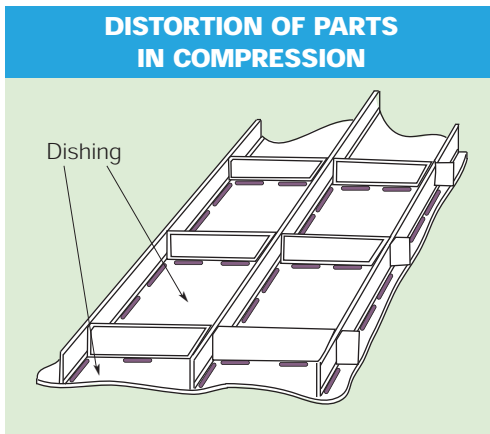

Figure 84

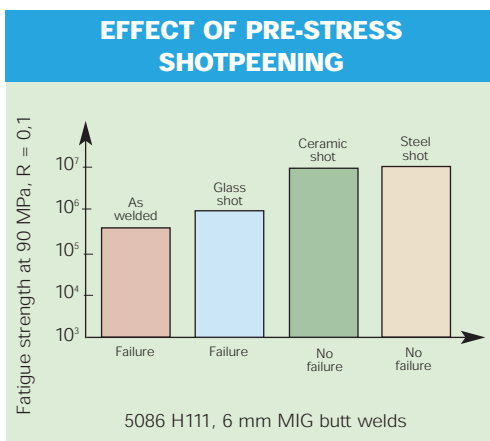

Figure 85

It is trickier to apply "shrinkage heat" to aluminium than to steel because of the high diffusion of heat. Unlike steel, aluminium does not change colour so the temperature must be checked with tallow or thermocolour pencils.

Shrinkage heat does not affect the mechanical properties of 5000 alloys in the O or H111 condition. However it anneals 6000 series alloys and so reduces their mechanical properties.

(27) Cf. figure 45, p. 65.

## 10. INSPECTION

The purpose of inspection is to evaluate the quality of fabricated products and more specifically to grade the quality of a weld against an acceptable level of defects.

The acceptable level of defects is determined by a number of parameters:

- the load modes and load conditions – static and dynamic,
- the levels and variations of stress,
- the safety of persons and property,
- the technical and financial consequences of failure,
- the options for routine operational inspection and control.

### 10.1 Approval procedures

Approval procedures are contractual but they also make reference to standards (if any) and to the regulations of classification societies, especially as regards the qualification of welders.

They may be complemented by the fabricator's own inhouse procedures, governing welding methods in particular.

Tensile and bending tests are conducted on test specimens following approval procedures laid down by the classification societies. These tests are very important as they can help:

- to detect a lack of fusion that is hard to identify by NDT testing, and
- to adjust parameters so as to limit defects.

### 10.2 Testing welded joints

The frequency and extent of weld testing will depend on a number of criteria, such as:

- structure,
- rate of stress,
- any loads imposed on the welds.

In the course of fabrication it is possible to perform:

- non-destructive tests including random X-ray testing (28), ultrasonic etc.,
- visual inspection and dye-penetration (29) which can be performed over the whole of some welds to detect incipient cracks,
- tests of mechanical properties and bending tests on specimens taken from batches of welded metal according to the current methods

(28) X-ray testing is not normally possible on fillet welds.

(29) According to NF A 09-120. Non-destructive tests. General principles of dye-penetration testing. June 1984.

(30) EN ISO 6520-1 Classification of geometric imperfections in metallic materials. Part 1: Fusion welding.

## 11. WELD IMPERFECTIONS

The causes of weld imperfections are numerous, and are a result of either the preparation of the metal or poor workmanship.

The most common defects encountered in aluminium welding are virtually the same as are found in the welding of steel: isolated cracks ('star cracks') or longitudinal cracks, incomplete penetration, poor bonding (fusion), porosity and undercuts.

Standards define weld imperfections based on measurements on a cross section (figure 86) of the weld and observations on its appearance.

An international nomenclature of defects has been established and is given in EN ISO 6520-1 (30) which lists 6 groups of imperfections, as shown in table 53, p. 104).

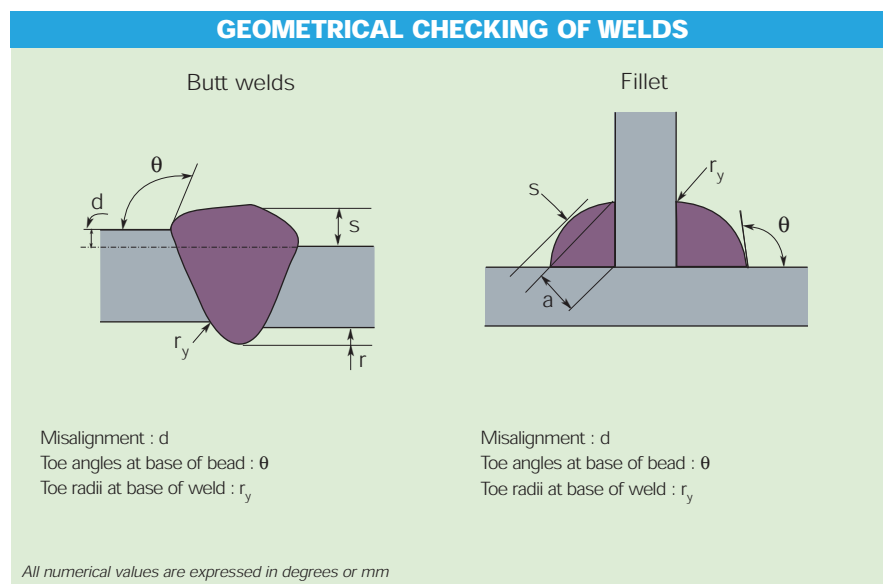

Figure 86

## GROUPS OF WELD IMPERFECTIONS



Group	Type of Imperfection
100	Cracks
200	Cavities and wormholes
300	Solid inclusions
400	Lack of fusion and penetration
500	Defects of shape
600	Sundry defects

Table 53

## 11.1 Common weld imperfections

Table 54 lists the most common imperfections together with their likely causes.

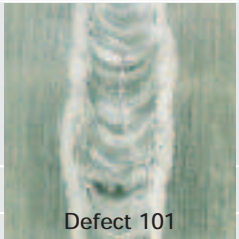
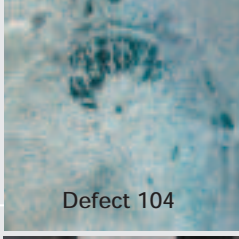
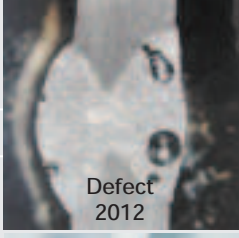
## TYPICAL WELD IMPERFECTIONS

N°	Type of Defect	Likely Cause	Photos of Imperfections
101	Cracks	Base alloy unsuitable Poor choice of filler metal Incorrect welding sequence Excessive clamping Sudden cooling	 Defect 101
104	Crater cracks	Pass finished with sudden arc cutoff	
2012	Irregular wormholes	Work inadequately degreased Work and/or filler wire dirty or wet Insufficient protection by inert gas (low gas flow or leak in the system) Pass begun on cold component High arc voltage Weld cooled too quickly	 Defect 104
2014	Aligned wormholes	Incomplete penetration (double pass) Temperature gradient between liner and work too abrupt Excessive gap between edges of the joint	 Defect 2012
300	Solid inclusions	Dirty metal (oxides, brush hairs)	
303	Oxide inclusions	Poor gas shielding Metal stored in poor conditions Castings	 Defect 300
3041	Tungsten inclusions (TIG)	Electrode diameter too small Poor handling by welder Excessive current density Poor quality of tungsten electrode	
402	Incomplete penetration	Inadequate cleaning (presence of oxide) Incorrect bevel preparation on thick work (too tight, excessive shoulder) Gap between workpieces too small (or inconsistent) Low current, especially at the start of the seam Welding speed too fast High arc voltage	 Defect 402

N°	Type of Defect	Likely Cause	Photos of Imperfections
4011	Lack of fusion on edges	High arc voltage Low current, especially at the start of the seam Work cold (difference in thickness between materials to be welded)	
502	Excessive thickness	Poor power control (poor U/I match) Welding speed too slow Poor edge preparation on thick work Insufficient starting current	
507	Misalignment	Work positioned incorrectly Incorrect welding sequence	
508	Angle defect	Excessive welding power Incorrect welding sequence	
509	Collapse	Wire speed too fast Torch speed too slow Poor torch guidance	
602	Splatter (or beads)	Incorrect arc control Problem in electrical contact to ground	

Table 54

## 11.2 Effect of weld imperfections on fatigue strength

Some weld defects have a significant impact on the fatigue strength of the weldment:

■ cracks (emergent or otherwise) and incomplete penetration are very serious flaws, as shown by tests carried out on weld defects <sup>[5]</sup> (figure 87),

■ defects of geometry, especially sudden breaks in curves (angle at

the base of the weld seam, misalignment etc.) aggravate stress intensity factors.

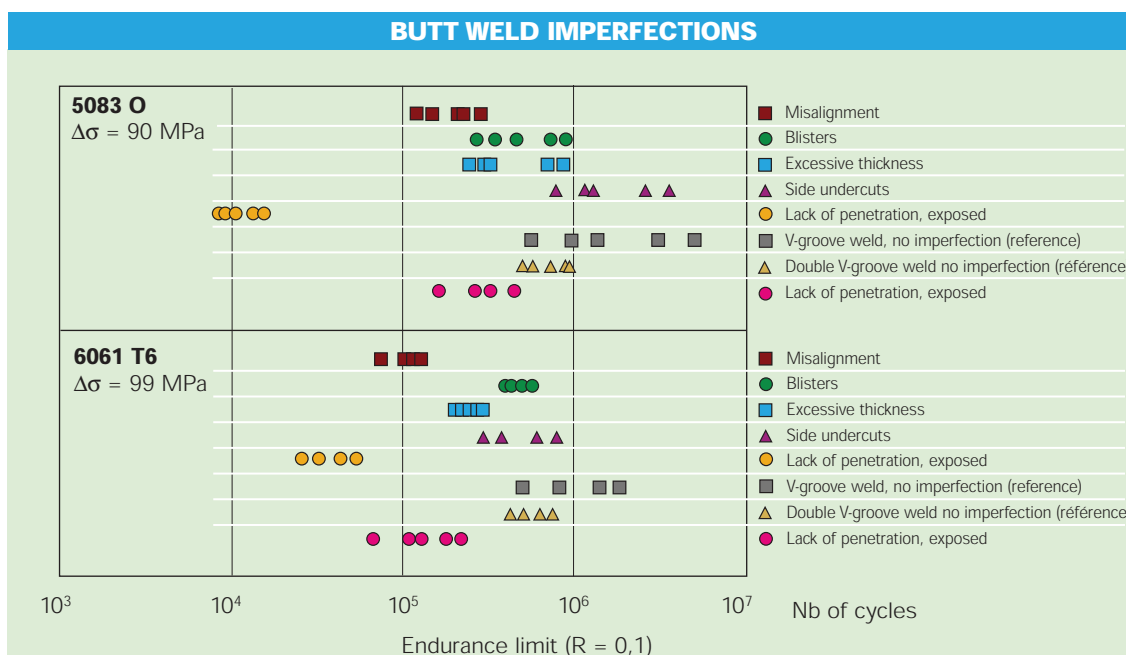

Figure 87

## 12. REPAIRS AND FITTINGS

European shipyards have responded to needs for the maintenance and modification of aluminium high speed ships by adapting to and specialising in this new activity [6, 7<sup>8</sup>].

These yards repair damage to ships and modify onboard installations. The very long service life of aluminium ships means that from time to time they must be adapted in line with changing conditions of service, new equipment must be installed etc.

Work on aluminium alloy structures is based on classical sheet metalworking operations as is commonly carried out on steel ships (and their equipment), e.g. sheet and plate cutting, preparing edges for welding, making welds, correcting distortion etc.

The rules discussed previously for aluminium alloy forming and welding apply equally to these operations.

A number of basic precautions should be taken when welding items that are being repaired or modified:

- clean surfaces near to the weld with great care, using a brush to remove all traces of paint, oil or fuel that could have fouled the plates,
- dry thoroughly before welding to remove all traces of moisture,
- weld under cover of weather and away from draughts; if necessary, work under a tarpaulin when these operations are carried out in dock,
- pay particular attention to the direction in which welds are made – this will limit distortion and minimise the risks of hot cracking due to shrinkage,
- select the correct welding process: TIG (for work less than 6 mm

thick) or MIG. TIG is more suitable for minor repairs where back access is difficult or impossible, being easier to use in such situations and providing better control of penetration than MIG.

For localised repairs such as a torn hull, the repair patch must be perfectly matched to the shape of the tear but will be bigger (achieved by hammering) to compensate for the contraction caused by welding. Without this precaution, the residual stress would attain a level where it would cause systematic cracking. The smaller the patch, the more pronounced this phenomenon.

### Important note:

Never work with a torch or electric arc on or in any enclosed space, tank etc. that has held water (including seawater) or which has been in contact with moisture without first airing or thoroughly ventilating it to disperse the hydrogen produced by possible corrosion of the metal in contact with water. Failure to take this precaution may lead to an explosion hazard with consequences that could prove catastrophic for the operators (31). It is also a mandatory precaution for any work on fuel oil tanks.

## 13. LASER WELDING

Since the early Nineties, the uses of welding by laser (32) have spread widely in shipbuilding [9].

### 13.1 Principle of the laser

The laser is a device that generates an intense beam of coherent monochromatic radiation. In welding machines, this radiation is concentrated to obtain power densities in excess of  $10^6 \text{ W.cm}^{-2}$  which is sufficient for the industrial welding of aluminium alloys.

This power is used to generate a capillary filled with metallic vapour whose walls are lined with liquid metal in fusion. The resulting weld pool bath is displaced and the liquid metal solidifies after the beam has passed, ensuring metallurgical continuity between the workpieces (figure 88).

### 13.2 Welding lasers

Two types of industrial laser are used for welding metals:

- **in CO<sub>2</sub> lasers** the active medium is a gaseous blend of carbon dioxide (CO<sub>2</sub>), nitrogen (N<sub>2</sub>) and helium (H<sub>2</sub>) at low pressure. The wavelength of the laser beam is 10.6 μm. Industrial CO<sub>2</sub> lasers can generate power ranging from 1.5 to 40 kW. The beam is transmitted by mirrors.

(31) The amount of hydrogen that builds up in a ballast tank can be considerable even though corrosion is only superficial. In a tank with sides 1 metre long for example, i.e. 5 m<sup>2</sup> of area in contact with water, superficial corrosion one micron deep releases 16.8 litres of hydrogen !!!

(32) Light Amplification by Stimulated Emission of Radiation.

■ **in Nd:YAG lasers** (Neodyme Yttrium Garnet), the active medium is a solid and the radiation wavelength is  $1.06 \mu\text{m}$ , with a maximum available power of 3 to 4 kW. Despite their low power, Nd:YAG lasers offer a number of advantages over  $\text{CO}_2$  lasers: the sources are more compact, and Nd:YAG beams can be carried by fibre optics which makes it possible to weld along complex paths using welding robots.

### 13.3 Laser welding of aluminium alloys

Aluminium alloys can be laser welded with no particular difficulty and at speeds as high as several metres per minute.

Laser welding offers a number of advantages :

- simplicity of preparation before welding,
- high welding speeds, several metres/minute on butt welds in 6 mm plate made from 5000 alloy,
- reduced distortion owing to the high welding speed and narrowness of the weldment,
- high penetration by the beam; it is possible to weld ( $\text{CO}_2$  laser) 5000 series plate up to 12 mm thick in a single pass,
- high mechanical properties of the weld: nearly 90 % of the parent metal on 5083 H116 and 70% for 6082 T6,
- different thicknesses can be welded,
- 'invisible' welding,
- good final condition (minimal finishing required),
- advanced automation.

Nevertheless laser welding requires close preparation tolerances and its energy efficiency is low.

### 13.4 Laser weldability of aluminium alloys

Aluminium alloys have a relatively low light absorption rate in the far-infrared: 3 % with the  $\text{CO}_2$  laser and 25 % with the Nd:YAG laser. However this coefficient of absorption rises rapidly above fusion temperature and is approximately 90 % when the material's vaporisation temperature is reached (figure 89).

For welding therefore, vaporisation of the metal must be initiated in the laser beam. Two very different types of interaction are observed according to the power density at the surface of the material (figure 90) :

#### COEFFICIENT OF REFLECTION OF LASER BEAMS

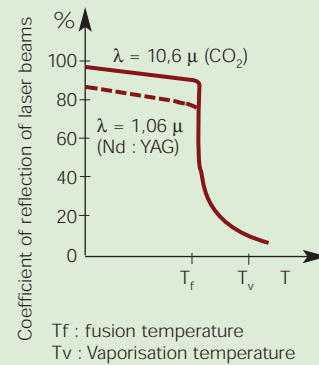

Figure 89

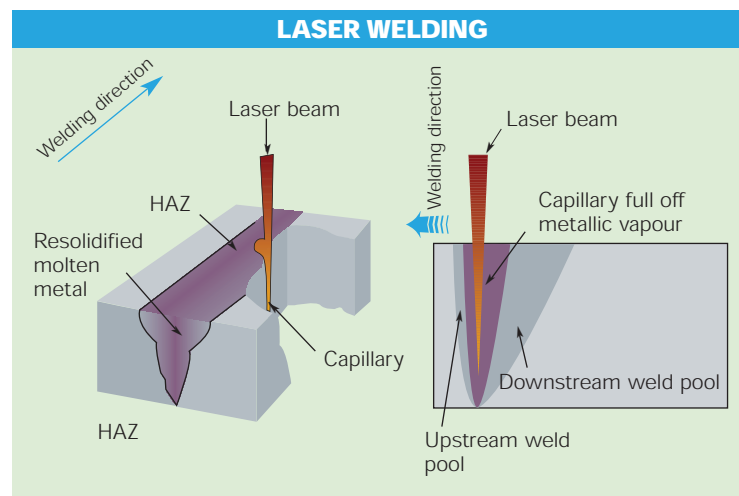

Figure 88

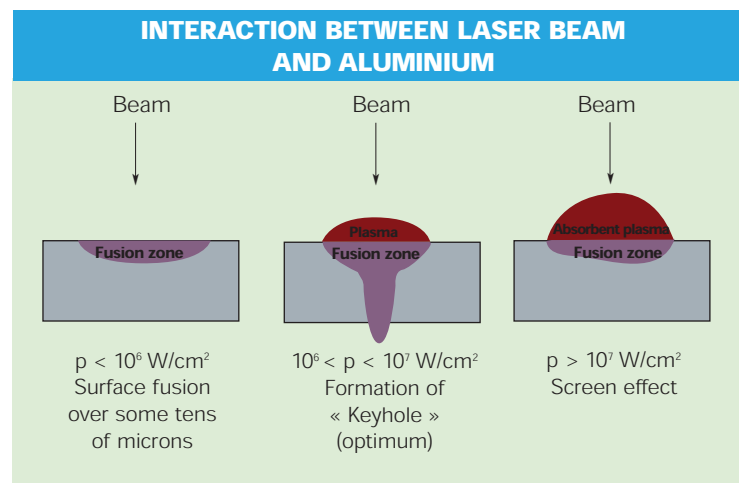

Figure 90



- at low densities, fusion is very superficial,
- at high densities a vapour capillary forms, i.e. a narrow and deep zone of fusion in the metal. It is this interaction which is needed for welding.

The threshold of interaction, i.e. the power density needed to form a vapour capillary, is of the order of  $10^6 \text{ W.cm}^{-2}$ . The value of this threshold depends on the composition of the alloy – alloys that contain magnesium in the 5000 series (5754, 5083, 5086, etc.) have a lower threshold of interaction than other alloys (figure 91) and can be welded with less power.

It is important to note that using too high a power density is counter-productive as the metal vapours will form a plasma that acts as a shield. This is particularly true of  $\text{CO}_2$  lasers.

A shielding gas must be used to prevent the immediate oxidation of the weld pool, and with  $\text{CO}_2$  lasers the best results are obtained with argon/helium blends or pure helium. Argon can also be used with Nd:YAG lasers.

## 14. FRICTION STIR WELDING (FSW)

Friction welding with a tool (33) was invented by the TWI (34), the first patent being filed in December 1991 [10].

It is clear that this has been a decisive advance in the joining of metals in general and aluminium alloys in particular. In under ten years this new welding technique has enjoyed significant industrial development and growth in a number of sectors including shipbuilding, aerospace and the railways [11].

Since 1995 many publications have appeared and presentations given on the applications of FSW welding in shipbuilding at international conferences on High Speed Ships made from aluminium [12]. These publications reflect the obvious interest shown by naval architects and yards in this new technique, one which is already making very significant changes to aluminium shipbuilding and giving it fresh impetus [13, 14].

### 14.1 Principle of friction stir welding

The process is a simple one, consisting of shearing the metal without melting it (it turns 'pasty') with a rotating tool that has a 'probe' or pin on a level slightly below that of the weld. As it rotates the tool stirs the metal of the workpieces together and discharges it to the rear where the weld thus formed is softened and consolidated.

The metal is made to flow by the heat from the friction of the rotating shoulder against the surface of the metal. The shoulder, which is larger in diameter than the probe, contains the moving particles of metal and maintains a pressure that prevents the metal from being ejected outside the welded zone (figure 92).

The very significant forces that are exerted on the work mean that it must be clamped very firmly to the table of the welding machine.

### 14.2 Microstructure of the FSW joint

The specific properties of the FSW joint are due to its microstructure which is very different from the microstructure of an arc weld (MIG or TIG) owing to the simple fact that there is no process of fusion / solidification.

An FSW weld has four very distinct zones (figure 93) [15] :

- **zone A**, outside the weld, is the parent metal of each of the workpieces on either side of the joint. Its structure is unaffected by welding,

- **zone B** is the heat affected zone. It does not undergo any plastic deformation. As with the HAZ of conventional MIG or TIG welds, its mechanical properties

(33) Friction stir welding (FSW).

(34) TWI: The Welding Institute.

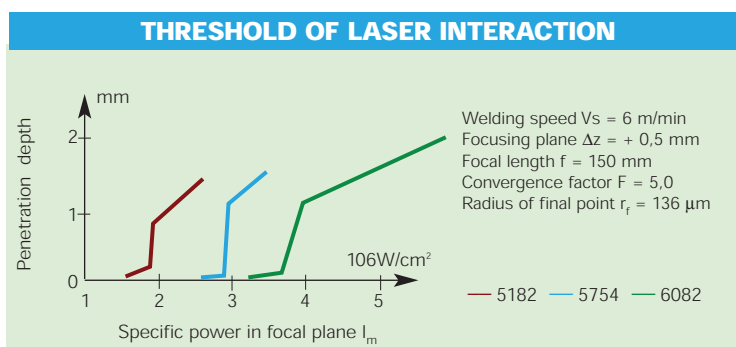

Figure 91



are low (figure 94). This zone is annealed in strain hardened alloys and over-aged in age hardened alloys (35). However no deformation occurs because the heating up of the metal and the temperature level attained are much lower than in arc welding,

■ **zone C** is the thermomechanically affected zone that has undergone plastic deformation and heating. The structure of this zone depends on a number of parameters including the type of alloy,

■ **zone D** is the "nugget" formed from recrystallised grains in which the metallurgical constituents of the parent alloys are dispersed. The grains are usually smaller than in the parent metal. This structure enhances the fatigue resistance of the welded joint.

In age hardened alloys the nugget is in a condition close to T4 (solution heat treated, natural ageing at ambient) (figure 95).

### 14.3 Comparisons with arc welding

The FSW process operates at a temperature below the melting point of the metal, offering a number of advantages:

■ **conditions of use** are simplified: surface preparation is confined to degreasing only. Where edge preparation is necessary, surfacing is adequate. The process requires no filler metal or shielding gas,

■ **the applications** of FSW are far more extensive than with arc welding: all types of aluminium alloy products can be welded, whether castings or wrought semis,

■ **the quality of the weld:** there are no risks of hot cracking (36) or porosity as hydrogen is not formed (37),

■ **the quality of the assemblies:** distortion is minimal owing to the low temperature levels and the fact that welding takes place in a solid medium,

(35) As a result the alloys are in the metallurgical condition indicated previously.

(36) It is possible to weld copper alloys (2000 and 7000 series).

(37) If hydrogen did form it would not be dissolved because its solubility in solid aluminium is zero.

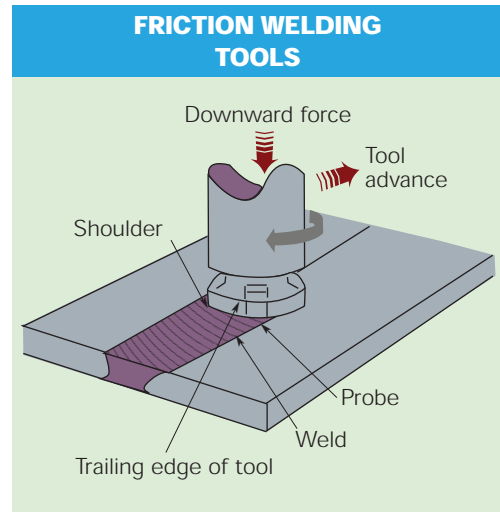

Figure 92

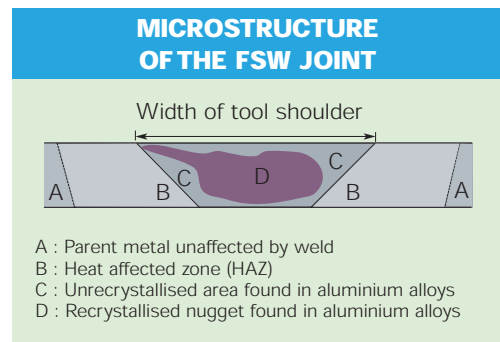

Figure 93

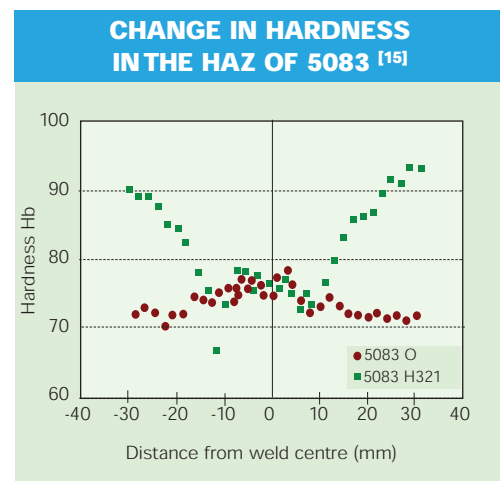

Figure 94

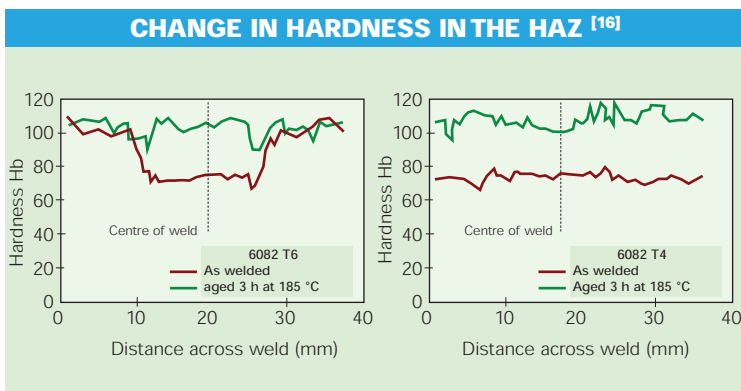

Figure 95

■ **environmental and working conditions:** there are no fumes, no flying particles of metal, no ozone emissions and no ultraviolet radiation. The process is also energy efficient, requiring about 20 % of the power of MIG welding.

Its present state of industrial development makes FSW highly suitable for prefabricating sub-assemblies such as deck sections, walls, panels etc. <sup>[17]</sup> *in the workshop* for subsequent installation in ships and assembly by conventional welding techniques such as MIG (38).

A prototype "portable" machine designed by the University of Adelaide in Australia with The Welding Institute was presented recently <sup>[18]</sup>. This is in fact a tool connected to a hydraulic motor and mounted on a trolley for welding hull plates 5 mm thick. However although the tool is "portable," the components to be butt welded must be firmly fixed to withstand the forces necessary for welding.

(38) A welding code is in the process of being approved by the classification societies.

## 14.4 Possibilities of welding with FSW

In its present state of advance, FSW allows the welding of material up to 25 mm thick. Research into 6000 series alloys has shown that it is possible to go up to 50 mm thick with a single head (figure 96), and 75 mm with two heads (figure 97).

Given the current level of industrial development of the process, FSW can be envisaged in a number of configurations for butt welds and 'invisible' welds as shown in figure 98.



Figure 96

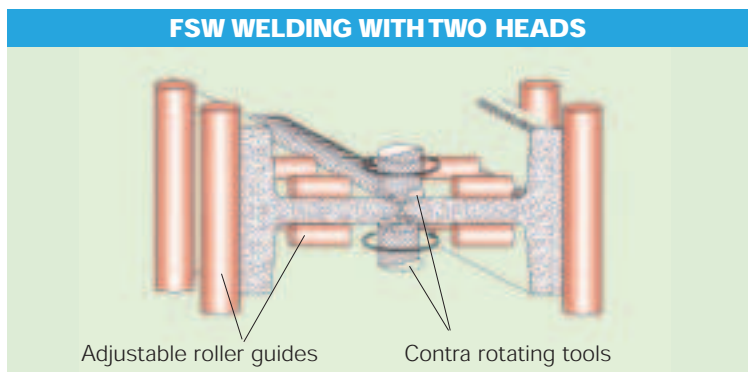

Figure 97

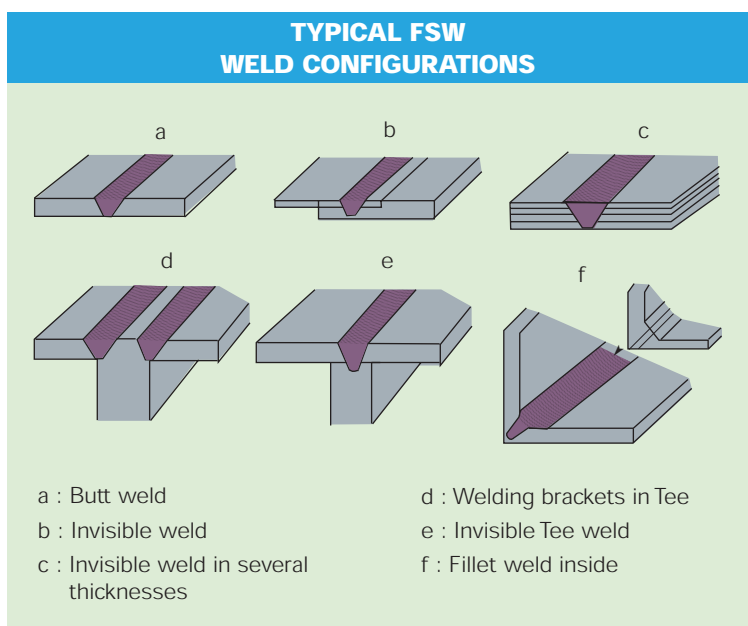

Figure 98

### MECHANICAL PROPERTIES OF WELDED 5083 AND 5383 6 MM THICK [20]

Alloy	Welding	R <sub>p0,2</sub> (MPa)	R <sub>m</sub> (MPa)	A %
5083 H116	MIG	134	287	12,8
	FSW	157	335	17
Sealium®	MIG	150	308	13,5
	FSW	165	354	17

Table 55

### LIMIT OF ENDURANCE ON 5383 (AT 10<sup>7</sup> CYCLES FOR R = 0.1) [11]

Alloy	Welding	Limit of Endurance (MPa)
Sealium®	Parent metal	228
	FSW	172
	MIG	144

Table 56

## 14.5 Performance of FSW welds

There have been numerous studies characterising the properties of FSW welds – their mechanical properties, fatigue strength and corrosion resistance of the weldment [19].

### ■ Mechanical properties

The mechanical properties of FSW welded metal are superior to those of MIG welded metal (table 55).

Fractures usually occur at the edge of the friction zone, never inside it, most probably because of the strain hardening caused by the base of the tool.

The limit of elasticity is at least 10% higher in FSW welded metal than MIG welded.

### ■ Fatigue resistance

The limit of endurance of FSW welded metal is superior to that of a MIG weld (figure 99) [21].

The limit of endurance of an FSW weld is always superior to that of a MIG welded joint, and this is true

for all alloys. This is because FSW ensures a very good connection between the joined workpieces. There is no 'sticking' (i.e. lack of fusion). It goes without saying that this applies only when the FSW joint is free from imperfections.

### LIMIT OF ENDURANCE OF FSW JOINTS

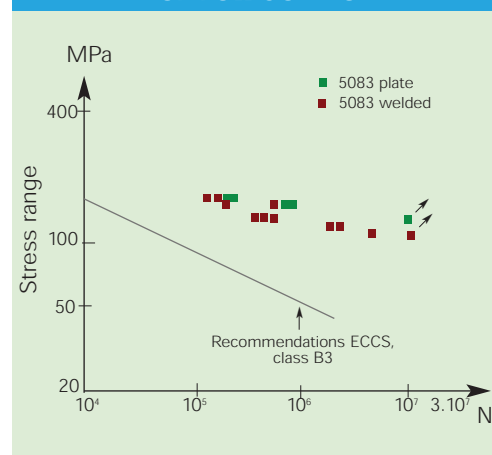

Figure 99

### ■ Corrosion resistance

Investigations carried out so far have not indicated any particular sensitivity to corrosion by FSW welds. Their resistance to corrosion is at least equal to that of MIG or TIG welds.

ENGINE AND DRIVE SHAFT BEARER



## 15. | STANDARDS

The main standards that govern the welding of aluminium are listed in table 57.

MAIN EUROPEAN STANDARDS FOR WELDING OF ALUMINIUM		
Reference	Date	Subject
BS EN 1011-4	Dec 2000	Welding. Recommendations for welding of metallic materials. Part 4: Arc welding of aluminium and aluminium alloys.
NF A 89-310	April 1973	Aluminium et alliages d'aluminium - Soudage - Assemblages élémentaires types - Critères de choix.
NF A 87-010	April 1973	Aluminium et alliages d'aluminium - Soudage - Préparation des bords.
BS EN 288-4/A1	August 1997	Specification and approval of welding procedures for metallic materials. Welding procedure tests for the arc welding of aluminium and its alloys.
NF A 89-220	April 1973	Aluminium et alliages d'aluminium - Soudage - Classification et contrôle des joints soudés.
BS 8118		Structural use of aluminium. Part 2. Specifications for materials, workmanship and protection.
BS EN ISO 9692-3	Dec 2001	Welding and allied processes. Recommendations for joint preparation. Part 3: Metal inert gas welding and tungsten inert gas welding of aluminium and its alloys. (ISO 9692-3:2000).
BS EN 12584	June 1999	Imperfections in oxyfuel flame cuts, laser beam cuts and plasma cuts. Terminology.
BS EN 30042 ISO 10042	July 1994	Arc-welded joints in aluminium and its weldable alloys. Guidance on quality levels for imperfections.
BS EN ISO 13919-2	Dec 2001	Welding -- Electron and laser beam welded joints -- Guidance on quality levels for imperfections -- Part 2: Aluminium and its weldable alloys (ISO 13919-2:2001).
BS EN ISO 6520-1	Dec 1998	Welding and allied processes -- Classification of geometric imperfections in metallic materials -- Part 1: Fusion welding (ISO 6520-1:1998).
NF EN 83-100-1	Dec 1995	Construction d'ensembles mécano soudés. Techniques de soudage. Partie 1 – Généralités : Terminologie, Classes de qualité de soudure – Etendue des contrôles.
BS EN 12062	1998	Non-destructive examination of welds. General rules for metallic materials.
BS EN 970	May 1997	Non-destructive examination of fusion welds. Visual examination.
NF A 09-120	June 1984	Essais non destructifs. Principe généraux de l'examen par ressuage.

Reference	Date	Subject
BS EN 1289	August 1998	Non-destructive examination of welds. Penetrant testing of welds. Acceptance levels.
BS EN 1712	Nov 1997	Non-destructive examination of welds. Ultrasonic examination of welded joints. Acceptance levels.
BS EN 1713	Sept 1998	Non-destructive examination of welds. Ultrasonic examination. Characterization of indications in welds.
BS EN 1714	Oct 1997	Non-destructive examination of welded joints. Ultrasonic examination of welded joints.
BS EN 1712/A1	February 2003	Non-destructive examination of welds. Ultrasonic examination of welded joints. Acceptance levels.
BS EN 1714/A1	February 2003	Non-destructive examination of welded joints. Ultrasonic examination of welded joints.
BS EN 444	April 1994	Non-destructive testing. General principles for radiographic examination of metallic materials by X- and gamma-rays.
BS EN 1435	Oct 1997	Non-destructive examination of welds. Radiographic examination of welded joints.
BS EN 12517	Sept 1998	Non-destructive examination of welds. Radiographic examination of welded joints. Acceptance levels.
BS EN 287-2	June 1992	Approval testing of welders for fusion welding. Aluminium and aluminium alloys.
BS EN 287-2/A1	August 1997	Approval testing of welders for fusion welding. Aluminium and aluminium alloys.
BS EN ISO 9956-10	Nov 1996	Specification and approval of welding procedures for metallic materials -- Part 10: Welding procedure specification for electron beam welding.
BS EN ISO 9956-11	Nov 1996	Specification and approval of welding procedures for metallic materials -- Part 11: Welding procedure specification for laser beam welding.
BS EN 12345	June 1999	Welding. Multilingual terms for welded joints with illustrations.
BS EN 1792	2003	Welding. Multilingual list of terms for welding and related processes.

Table 57

## Bibliography

- [1] "Soudure et chaudronnerie d'aluminium", *Revue de l'aluminium*, No. 99, March 1938, pp. 1128-1135.
- [2] "Le soudage à l'arc des métaux légers avec électrode fusible enrobée", CHARLES GUINARD, *Revue de l'aluminium*, No. 167, June 1950, pp. 237-244.
- [3] "Die Fügetechniken des Aluminiums im Laufe der Jahrzehnte", G. AICHELE, *Aluminium*, Vol. 75, pp. 743-753, 1999.
- [4] "Construction of the All-Welded Twin-Screw Auxiliary Motor Yacht", J. G. YOUNG, *British Welding Journal*, January 1955, pp. 1-18.
- [5] "Nocivité des de soudage sur éprouvettes soudées MIG" D. ALBERT, C. HANTRAIS, M. MÉDIOUNI, M. TRICOT, *Rapport Pechiney CRV 3535*, December 1994.
- [6] "Repair yards show their versatility", *Speed at Sea*, April 1998.
- [7] "Routine repairs provide annual returns", *Speed at Sea*, January 1999.
- [8] "Aluminium skills are part of routine workload", *Speed at Sea*, October 2000.
- [9] "Developments in welding techniques for aluminium alloys", J. D. RUSSEL, C. J. DAWES, R. L. JONES, TWI, *Conference Southampton* 1996.
- [10] "Improvements relating to friction welding", W M THOMAS, E D NICHOLAS, J C NEEDHAM, MG MURCH, P TEMPLE SMITH, CJ DAWES, (TWI), Patent GB 91 25978.8, International PCT/GB92/02203 and European Patent Specification 0 615 480 B1.
- [11] "Application of Friction Stir Welding for manufacture of aluminium ferries", S. W. KALLE, E. D. NICHOLAS, P. M. BURLING, TWI, *4th International Forum on Aluminium Ships*, New Orleans, May 2000.

[12] "4th International Forum on Aluminium Ships", New Orleans, May 2000

"European Shipbuilding in the 21st Century", London, December 2000.

"The Third International Forum on Aluminium Ships", Haugesund, May 1998.

"Lightweight Construction – Latest Developments", The Royal Institution of Naval Architects, London February 2000.

[13] "Studies extend Friction Stir Welding potential", *Speed at Sea*, October 1998, p. 45.

[14] "Friction Stir benefits include cost saving", P. HYNDS, *Speed at Sea*, October 1999, p. 33.

[15] "Friction Stir Welding in aluminium alloys, preliminary microstructural assessment", P L THREADGILL, *TWI Bulletin*, Vol. 28 (2), March 1997, pp. 30–33 .

[16] "Friction Stir Welding – Weld properties and manufacturing techniques", Proc INALCO-7, Cambridge April 1998, pp. 171–181.

[17] "Application of prefabricated Friction Stir Welding panels in catamaran building", O. T. MIDLING, J. S. KVALE, S. OMA, *4th International Forum on Aluminium Ships*, New Orleans, May 2000.

[18] "Exploiting friction stir welding in explosevely-formed aluminium boat hull construction", I. HENDERSON, *Joints in aluminium*, INALCO 98, 1998, pp. 261-267.

[19] "Friction Stir Welding – The state of the art", P. L. THREADGILL; *Report TWI 7417.01/99/1012*

[20] *Pechiney Report CRV* February 1999.

[21] "Friction Stir Welding aluminium alloy 5083, Increased welding speed", C. J. DAWES, E. J. R. SPURGIN, D. G. STAINES, *Report TWI 7735.1/98/993.2*.



MARINA AT TRINITÉ-SUR-MER